

DATA SHEET

TPM749

Microcontroller with TrackPoint™
microcode from IBM

Product specification

1996 May 01

Data Handbook IC20

Microcontroller with TrackPoint™ microcode from IBM

TPM749

DESCRIPTION

The Philips Semiconductors TPM749 is a small package, low cost, ROM-coded 80C51 with IBM®'s TrackPoint™ pointing algorithms and control code. TrackPoint is the result of years of human factors research and innovation at IBM. The result is a "velocity sensitive" pointing solution more efficient and easier to use than "position sensitive" devices such as the mouse, the trackball, or the touchpad.

IBM has licensed Philips Semiconductors to sell microcontrollers with TrackPoint code. By purchasing a TPM from Philips, the purchaser becomes a sub-licensee of Philips. The selling price of Philips' TPM includes the royalties for IBM's intellectual property, which Philips in turn pays to IBM. Customers for TPMs do not need to sign any licensing agreement with either IBM or Philips. This code is the intellectual property of IBM, which is covered by numerous patents, and must be treated accordingly.

The TPM is fabricated with Philips high-density CMOS technology. Philips epitaxial substrate minimizes CMOS latch-up sensitivity.

The TPM contains a 2k × 8 ROM, a 64 × 8 RAM, 21 I/O lines, a 16-bit auto-reload counter/timer, a fixed-priority level interrupt structure, an on-chip oscillator, a five channel multiplexed 8-bit A/D converter, and an 8-bit PWM output.

The TPM supports two power reduction modes of operation referred to as the idle mode and the power-down mode.

FEATURES

- 80C51 based architecture
- Small package sizes
 - 28-pin Shrink Small Outline Package (SSOP)
 - 28-pin PLCC
- Low power consumption:
 - Normal operation: less than 11mA @ 5V, 12MHz
 - Idle mode
 - Power-down mode
- 2k × 8 ROM
- 64 × 8 RAM
- 16-bit auto reloadable counter/timer
- 5-channel 8-bit A/D converter
- 8-bit PWM output/timer
- 10-bit fixed-rate timer
- CMOS and TTL compatible

PIN CONFIGURATION

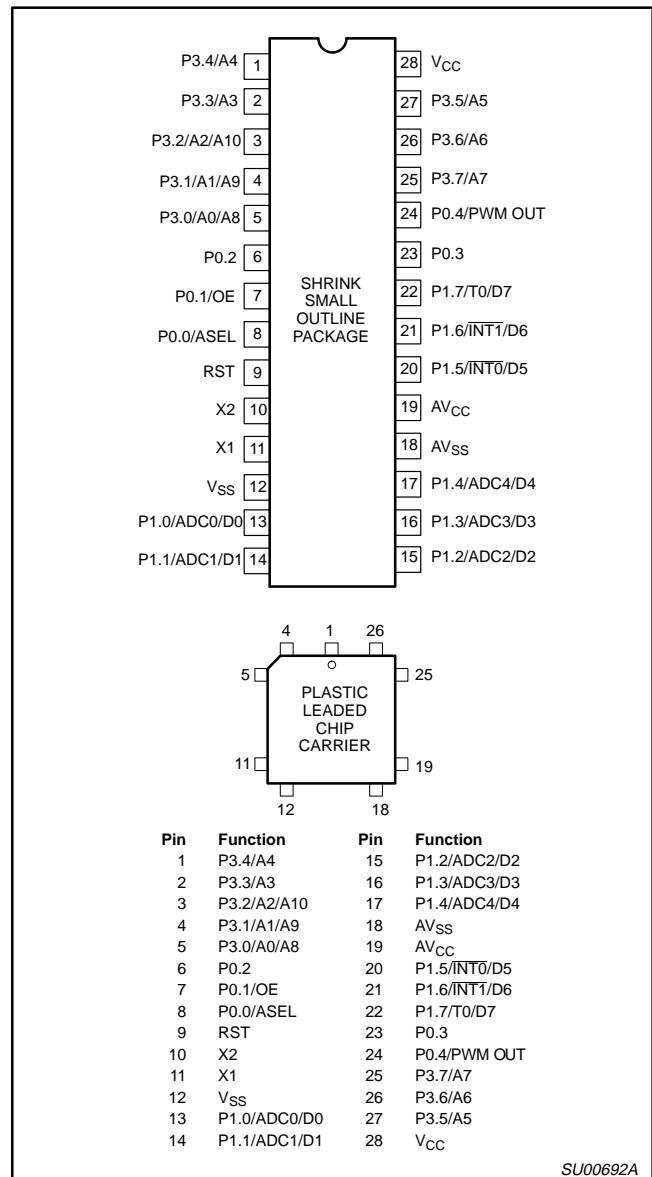

SU00692A

ORDERING INFORMATION

ORDERING CODE	TEMPERATURE RANGE AND PACKAGE	DRAWING NUMBER
PTPM749 A	0 to +70°C, Plastic Leaded Chip Carrier	SOT261-3
PTPM749 DB	0 to +70°C, Shrink Small Outline Package	SOT341-1

For compatible pointing device, contact:

COMPANY	CONTACT	TELEPHONE
Bokam Engineering	Ms. Jane Kamenster	(714)513-2200
CTS Corporation	Mr. Dave Poole	(219)589-7169

IBM is a registered trademark, and TrackPoint is a trademark of IBM Corporation.

Microcontroller with TrackPoint™ microcode from IBM

TPM749

PIN DESCRIPTION

MNEMONIC	PIN NO.	TYPE	NAME AND FUNCTION
V _{SS}	12	I	Circuit Ground Potential.
V _{CC}	28	I	Supply voltage during normal, idle, and power-down operation.
P0.0–P0.4	8–6 23, 24	I/O	<p>Port 0: Port 0 is a 5-bit bidirectional port. Port 0.0–P0.2 are open drain. Port 0.0–P0.2 pins that have 1s written to them float, and in that state can be used as high-impedance inputs. P0.3–P0.4 are bidirectional I/O port pins with internal pull-ups. These pins are driven low if the port register bit is written with a 0. The state of the pin can always be read from the port register by the program. Port 0.3 and 0.4 have internal pull-ups that function identically to port 3. Pins that have 1s written to them are pulled high by the internal pull-ups and can be used as inputs.</p> <p>While P0.0 and P0.1 differ from “standard TTL” characteristics, they are close enough for the pins to still be used as general-purpose I/O.</p>
	6	I	V_{PP} (P0.2) – Programming voltage input.
	7	I	OE (P0.1) – Input which specifies verify mode (output enable). OE = 1 output enabled (verify mode).
	8	I	ASEL (P0.0) – Input which indicates which bits of the EPROM address are applied to port 3. ASEL = 0 low address byte available on port 3. ASEL = 1 high address byte available on port 3 (only the three least significant bits are used).
P1.0–P1.7	13–17, 20–22	I/O	<p>Port 1: Port 1 is an 8-bit bidirectional I/O port with internal pull-ups. Port 1 pins that have 1s written to them are pulled high by the internal pull-ups and can be used as inputs. P0.3–P0.4 pins are bidirectional I/O port pins with internal pull-ups. As inputs, port 1 pins that are externally pulled low will source current because of the internal pull-ups. (See DC Electrical Characteristics: I_{IL}). Port 1 also serves the special function features of the SC80C51 family as listed below:</p>
	20	I	INT0 (P1.5): External interrupt.
	21	I	INT1 (P1.6): External interrupt.
	22	I	T0 (P1.7): Timer 0 external input.
	13–17	I	<p>ADC0 (P1.0)–ADC4 (P1.4): Port 1 also functions as the inputs to the five channel multiplexed A/D converter. These pins can be used as outputs only if the A/D function has been disabled. These pins can be used as digital inputs while the A/D converter is enabled.</p> <p>Port 1 serves to output the addressed EPROM contents in the verify mode and accepts as inputs the value to program into the selected address during the program mode.</p>
P3.0–P3.7	5–1, 27–25	I/O	<p>Port 3: Port 3 is an 8-bit bidirectional I/O port with internal pull-ups. Port 3 pins that have 1s written to them are pulled high by the internal pull-ups and can be used as inputs. As inputs, port 3 pins that are externally being pulled low will source current because of the pull-ups. (See DC Electrical Characteristics: I_{IL}). Port 3 also functions as the address input for the EPROM memory location to be programmed (or verified). The 11-bit address is multiplexed into this port as specified by P0.0/ASEL.</p>
RST	9	I	<p>Reset: A high on this pin for two machine cycles while the oscillator is running resets the device. An internal diffused resistor to V_{SS} permits a power-on RESET using only an external capacitor to V_{CC}. After the device is reset, a 10-bit serial sequence, sent LSB first, applied to RESET, places the device in the programming state allowing programming address, data and V_{PP} to be applied for programming or verification purposes. The RESET serial sequence must be synchronized with the X1 input.</p>
X1	11	I	<p>Crystal 1: Input to the inverting oscillator amplifier and input to the internal clock generator circuits. X1 also serves as the clock to strobe in a serial bit stream into RESET to place the device in the programming state.</p>
X2	10	O	Crystal 2: Output from the inverting oscillator amplifier.
AV _{CC} ¹	19	I	Analog supply voltage and reference input.
AV _{SS} ¹	18	I	Analog supply and reference ground.

NOTE:

1. AV_{SS} (reference ground) must be connected to 0V (ground). AV_{CC} (reference input) cannot differ from V_{CC} by more than ±0.2V, and must be in the range 4.5V to 5.5V.

Microcontroller with TrackPoint™ microcode from IBM

TPM749

SCHEMATIC OF TrackPoint SYSTEM WITH PHILIPS TPM749

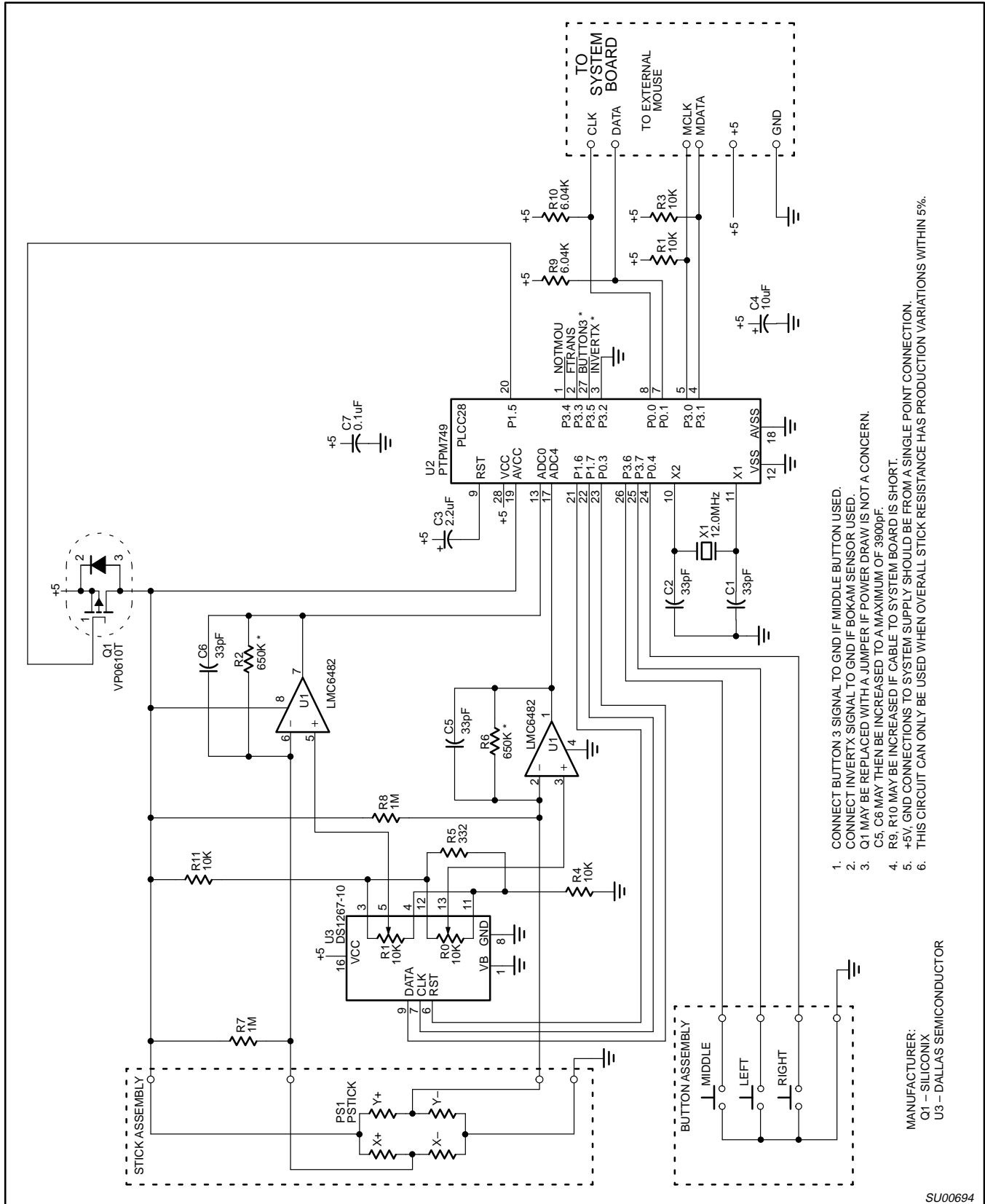

1. CONNECT BUTTON 3 SIGNAL TO GND IF MIDDLE BUTTON USED.
2. CONNECT INVERTX SIGNAL TO GND IF BOKAM SENSOR USED.
3. Q1 MAY BE REPLACED WITH A JUMPER IF POWER DRAW IS NOT A CONCERN.
4. R9, R10 MAY BE INCREASED TO A MAXIMUM OF 3900pF.
5. +5V, GND CONNECTIONS TO SYSTEM SUPPLY SHOULD BE FROM A SINGLE POINT CONNECTION.
6. THIS CIRCUIT CAN ONLY BE USED WHEN OVERALL STICK RESISTANCE HAS PRODUCTION VARIATIONS WITHIN 5%.

SU00694

Microcontroller with TrackPoint™ microcode from IBM

TPM749

OSCILLATOR CHARACTERISTICS

X1 and X2 are the input and output, respectively, of an inverting amplifier which can be configured for use as an on-chip oscillator.

To drive the device from an external clock source, X1 should be driven while X2 is left unconnected. There are no requirements on the duty cycle of the external clock signal, because the input to the internal clock circuitry is through a divide-by-two flip-flop. However, minimum and maximum high and low times specified in the data sheet must be observed.

IDLE MODE

The TPM includes the 80C51 power-down and idle mode features. In idle mode, the CPU puts itself to sleep while all of the on-chip peripherals except the A/D and PWM stay active. The functions that continue to run while in the idle mode are Timer 0, Timer 1, and the interrupts. The instruction to invoke the idle mode is the last instruction executed in the normal operating mode before the idle mode is activated. The CPU contents, the on-chip RAM, and all of the special function registers remain intact during this mode. The idle mode can be terminated either by any enabled interrupt (at which time the process is picked up at the interrupt service routine and continued), or by a hardware reset which starts the processor in the same manner as a power-on reset. Upon powering-up the circuit, or exiting from idle mode, sufficient time must be allowed for stabilization of the internal analog reference voltages before an A/D conversion is started.

POWER-DOWN MODE

In the power-down mode, the oscillator is stopped and the instruction to invoke power-down is the last instruction executed. Only the contents of the on-chip RAM are preserved. A hardware reset is the only way to terminate the power-down mode. The control bits for the reduced power modes are in the special function register PCON.

Table 1. External Pin Status During Idle and Power-Down Modes

MODE	Port 0*	Port 1	Port 2
Idle	Data	Data	Data
Power-down	Data	Data	Data

* Except for PWM output (P0.4).

I/O Ports

The I/O pins provided by the TPM consist of port 0, port 1, and port 3.

Port 0

Port 0 is a 5-bit bidirectional I/O port and includes alternate functions on some pins of this port. Pins P0.3 and P0.4 are provided with internal pullups while the remaining pins (P0.0, P0.1, and P0.2) have open drain output structures. The alternate function for port P0.4 is PWM output.

If the alternate function PWM is not being used, then this pin may be used as an I/O port.

Port 1

Port 1 is an 8-bit bidirectional I/O port whose structure is identical to the 80C51, but also includes alternate input functions on all pins. The alternate pin functions for port 1 are:

- P1.0-P1.4 - ADC0-ADC4 - A/D converter analog inputs
- P1.5 INT0 - external interrupt 0 input
- P1.6 INT1 - external interrupt 1 input
- P1.7 - T0 - timer 0 external input

If the alternate functions INT0, INT1, or T0 are not being used, these pins may be used as standard I/O ports. It is necessary to connect AVCC and AVSS to VCC and VSS, respectively, in order to use P1.5, P1.6, and P1.7 pins as standard I/O pins. When the A/D converter is enabled, the analog channel connected to the A/D may not be used as a digital input; however, the remaining analog inputs may be used as digital inputs. They may not be used as digital outputs. While the A/D is enabled, the analog inputs are floating.

Port 3

Port 3 is an 8-bit bidirectional I/O port whose structure is identical to the 80C51. Note that the alternate functions associated with port 3 of the 80C51 have been moved to port 1 of the TPM (as applicable). See Figure 1 for port bit configurations.

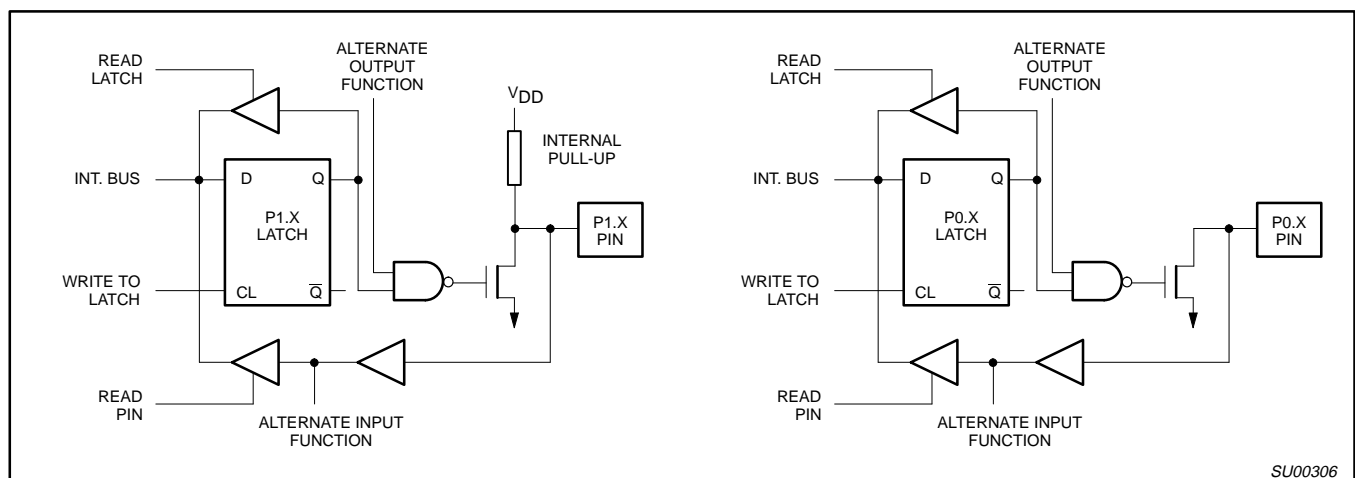

Figure 1. Port Bit Latches and I/O Buffers

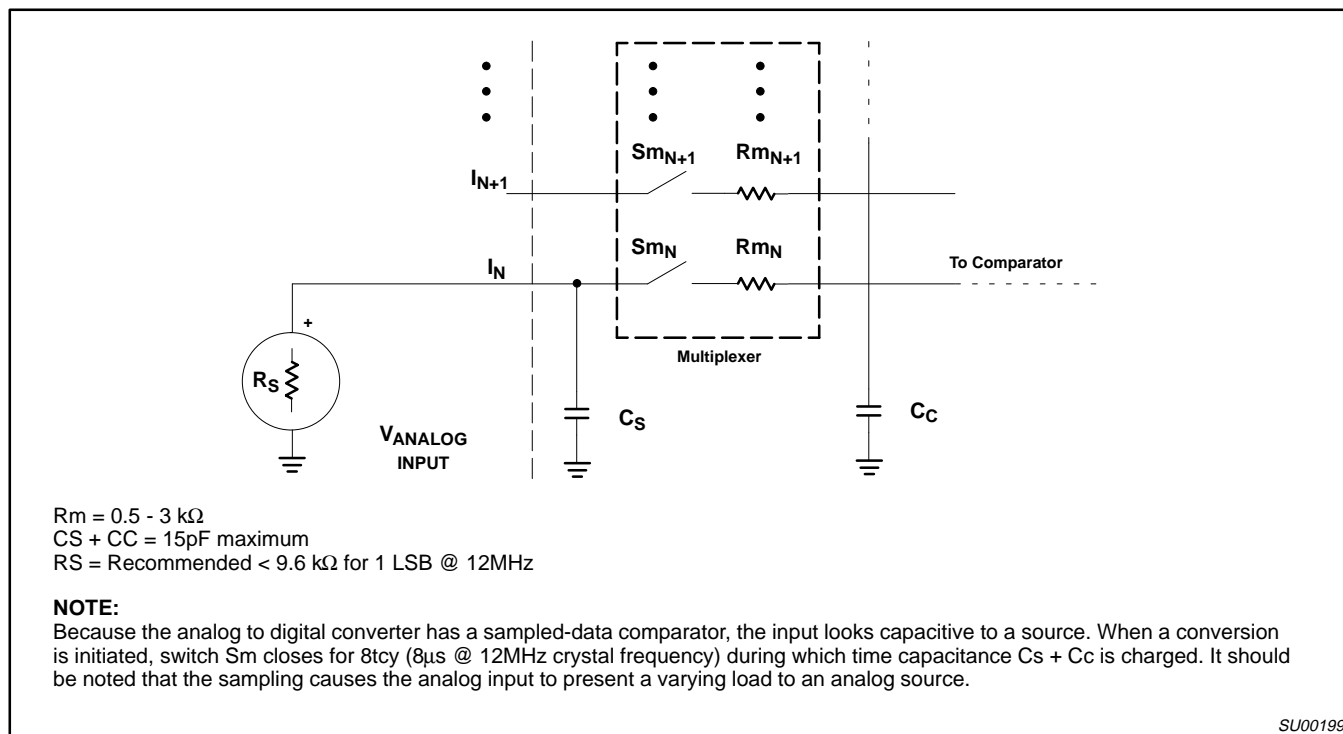

Figure 2. A/D Input: Equivalent Circuit

A/D CONVERTER PARAMETER DEFINITIONS

The following definitions are included to clarify some specifications given and do not represent a complete set of A/D parameter definitions.

Absolute Accuracy Error

Absolute accuracy error of a given output is the difference between the theoretical analog input voltage to produce a given output and the actual analog input voltage required to produce the same code. Since the same output code is produced by a band of input voltages, the "required input voltage" is defined as the midpoint of the band of input voltage that will produce that code. Absolute accuracy error not specified with a code is the maximum over all codes.

Nonlinearity

If a straight line is drawn between the end points of the actual converter characteristics such that zero offset and full scale errors are removed, then non-linearity is the maximum deviation of the code transitions of the actual characteristics from that of the straight line so constructed. This is also referred to as relative accuracy and also integral non-linearity.

Differential Non-Linearity

Differential non-linearity is the maximum difference between the actual and ideal code widths of the converter. The code widths are the differences expressed in LSB between the code transition points, as the input voltage is varied through the range for the complete set of codes.

Gain Error

Gain error is the deviation between the ideal and actual analog input voltage required to cause the final code transition to a full-scale output code after the offset error has been removed. This may sometimes be referred to as full scale error.

Offset Error

Offset error is the difference between the actual input voltage that causes the first code transition and the ideal value to cause the first code transition. This ideal value is 1/2 LSB above V_{ref-} .

Channel to Channel Matching

Channel to channel matching is the maximum difference between the corresponding code transitions of the actual characteristics taken from different channels under the same temperature, voltage and frequency conditions.

Crosstalk

Crosstalk is the measured level of a signal at the output of the converter resulting from a signal applied to one deselected channel.

Total Error

Maximum deviation of any step point from a line connecting the ideal first transition point to the ideal last transition point.

Relative Accuracy

Relative accuracy error is the deviation of the ADC's actual code transition points from the ideal code transition points on a straight line which connects the ideal first code transition point and the final code transition point, after nullifying offset error and gain error. It is generally expressed in LSBs or in percent of FSR.

Microcontroller with TrackPoint™ microcode from IBM

TPM749

ABSOLUTE MAXIMUM RATINGS^{1, 3, 4}

PARAMETER	RATING	UNIT
Storage temperature range	-65 to +150	°C
Voltage from V_{CC} to V_{SS}	-0.5 to +6.5	V
Voltage from any pin to V_{SS} (except V_{PP})	-0.5 to $V_{CC} + 0.5$	V
Power dissipation	1.0	W
Voltage from V_{PP} pin to V_{SS}	-0.5 to + 13.0	V

NOTES ON PAGE 8.

DC ELECTRICAL CHARACTERISTICS $T_{amb} = 0^{\circ}\text{C}$ to $+70^{\circ}\text{C}$, $AV_{CC} = 5\text{V} \pm 5$, $AV_{SS} = 0\text{V}$ ⁴ $V_{CC} = 5\text{V} \pm 10\%$, $V_{SS} = 0\text{V}$

SYMBOL	PARAMETER	TEST CONDITIONS	LIMITS ⁴			UNIT
			MIN	TYP ¹	MAX	
I_{CC}	Supply current (see Figure 5)					
Inputs						
V_{IL}	Input low voltage		-0.5		$0.2V_{CC}-0.1$	V
V_{IH}	Input high voltage, except X1, RST		$0.2V_{CC}+0.9$		$V_{CC}+0.5$	V
V_{IH1}	Input high voltage, X1, RST		$0.7V_{CC}$		$V_{CC}+0.5$	V
V_{IL1}	P0.2 Input low voltage		-0.5		$0.3V_{CC}$	V
V_{IH2}	Input high voltage		$0.7V_{CC}$		$V_{CC}+0.5$	V
Outputs						
V_{OL}	Output low voltage, ports 1, 3, 0.3, and 0.4 (PWM disabled)	$I_{OL} = 1.6\text{mA}^2$			0.45	V
V_{OL1}	Output low voltage, port 0.2	$I_{OL} = 3.2\text{mA}^2$			0.45	V
V_{OH}	Output high voltage, ports 1, 3, 0.3, and 0.4 (PWM disabled)	$I_{OH} = -60\mu\text{A}$, $I_{OH} = -25\mu\text{A}$ $I_{OH} = -10\mu\text{A}$	2.4 $0.75V_{CC}$ $0.9V_{CC}$			V V V
V_{OH2}	Output high voltage, P0.4 (PWM enabled)	$I_{OH} = -400\mu\text{A}$ $I_{OH} = -40\mu\text{A}$	2.4 $0.9V_{CC}$			V V
V_{OL2}	Port 0.0 and 0.1 – Drivers Output low voltage	$I_{OL} = 3\text{mA}$ (over V_{CC} range)			0.4	V
C	Driver, receiver combined: Capacitance				10	pF
I_{IL}	Logical 0 input current, ports 1, 3, 0.3, and 0.4 (PWM disabled) ¹¹	$V_{IN} = 0.45\text{V}$			-50	μA
I_{TL}	Logical 1 to 0 transition current, ports 1, 3, 0.3 and 0.4 ¹¹	$V_{IN} = 2\text{V}$			-650	μA
I_{LI}	Input leakage current, port 0.0, 0.1 and 0.2	$0.45 < V_{IN} < V_{CC}$			± 10	μA
R_{RST}	Reset pull-down resistor		25		175	$\text{k}\Omega$
C_{IO}	Pin capacitance	Test freq = 1MHz, $T_{amb} = 25^{\circ}\text{C}$			10	pF
I_{PD}	Power-down current ⁵	$V_{CC} = 2$ to 5.5V $V_{CC} = 2$ to 6.0V			50	μA

NOTES ON FOLLOWING PAGE.

Microcontroller with TrackPoint™ microcode from IBM

TPM749

DC ELECTRICAL CHARACTERISTICS (Continued)T_{amb} = 0°C to +70°C, AV_{CC} = 5V ±5, AV_{SS} = 0V⁴V_{CC} = 5V ± 10%, V_{SS} = 0V

SYMBOL	PARAMETER	TEST CONDITIONS	LIMITS ⁴			UNIT
			MIN	TYP ¹	MAX	
Analog Inputs (A/D guaranteed only with quartz window covered.)						
AV _{CC}	Analog supply voltage ¹⁰	AV _{CC} = V _{CC} ±0.2V	4.5		5.5	V
AI _{CC}	Analog operating supply current	AV _{CC} = 5.12V			3 ⁹	mA
AV _{IN}	Analog input voltage		AV _{SS} -0.2		AV _{CC} +0.2	V
C _{IA}	Analog input capacitance				15	pF
t _{ADS}	Sampling time				8t _{CY}	s
t _{ADC}	Conversion time				40t _{CY}	s
Analog Inputs (A/D guaranteed only with quartz window covered.) (Continued)						
R	Resolution				8	bits
E _{RA}	Relative accuracy				±1	LSB
OS _e	Zero scale offset				±1	LSB
G _e	Full scale gain error				0.4	%
M _{CTC}	Channel to channel matching				±1	LSB
C _t	Crosstalk	0–100kHz			-60	dB

NOTES:

- Stresses above those listed under Absolute Maximum Ratings may cause permanent damage to the device. This is a stress rating only and functional operation of the device at these or any conditions other than those described in the AC and DC Electrical Characteristics section of this specification is not implied.
- Under steady state (non-transient) conditions, I_{OL} must be externally limited as follows:

Maximum I _{OL} per port pin:	10mA
Maximum I _{OL} per 8-bit port:	26mA
Maximum total I _{OL} for all outputs:	67mA

 If I_{OL} exceeds the test condition, V_{OL} may exceed the related specification. Pins are not guaranteed to sink current greater than the listed test conditions.
- This product includes circuitry specifically designed for the protection of its internal devices from the damaging effects of excessive static charge. Nonetheless, it is suggested that conventional precautions be taken to avoid applying greater than the rated maxima.
- Parameters are valid over operating temperature range unless otherwise specified. All voltages are with respect to V_{SS} unless otherwise noted.
- Power-down I_{CC} is measured with all output pins disconnected; port 0 = V_{CC}; X2, X1 n.c.; RST = V_{SS}.
- I_{CC} is measured with all output pins disconnected; X1 driven with t_{CLCH}, t_{CHCL} = 5ns, V_{IL} = V_{SS} + 0.5V, V_{IH} = V_{CC} - 0.5V; X2 n.c.; RST = port 0 = V_{CC}. I_{CC} will be slightly higher if a crystal oscillator is used.
- Idle I_{CC} is measured with all output pins disconnected; X1 driven with t_{CLCH}, t_{CHCL} = 5ns, V_{IL} = V_{SS} + 0.5V, V_{IH} = V_{CC} - 0.5V; X2 n.c.; port 0 = V_{CC}; RST = V_{SS}.
- Load capacitance for ports = 80pF.
- The resistor ladder network is not disconnected in the power down or idle modes. Thus, to conserve power, the user may remove AV_{CC}.
- If the A/D function is not required, or if the A/D function is only needed periodically, AV_{CC} may be removed without affecting the operation of the digital circuitry. Contents of ADCON and ADAT are not guaranteed to be valid. If AV_{CC} is removed, the A/D inputs must be lowered to less than 0.5V. Digital inputs on P1.0–P1.4 will not function normally.
- These parameters do not apply to P1.0–P1.4 if the A/D function is enabled.

Microcontroller with TrackPoint™ microcode from IBM

TPM749

AC ELECTRICAL CHARACTERISTICS

$T_{amb} = 0^{\circ}\text{C to } +70^{\circ}\text{C}$, $V_{CC} = 5\text{V} \pm 10\%$, $V_{SS} = 0\text{V}^{4,8}$

SYMBOL	PARAMETER	12MHz CLOCK		VARIABLE CLOCK		UNIT
		MIN	MAX	MIN	MAX	
$1/t_{CLCL}$	Oscillator frequency:			3.5	12	MHz
External Clock (Figure 3)						
t_{CHCX}	High time	20		20		ns
t_{CLCX}	Low time	20		20		ns
t_{CLCH}	Rise time		20		20	ns
t_{CHCL}	Fall time		20		20	ns

EXPLANATION OF THE AC SYMBOLS

Each timing symbol has five characters. The first character is always 't' (= time). The other characters, depending on their positions, indicate the name of a signal or the logical status of that signal. The designations are:

- C – Clock
- D – Input data
- H – Logic level high
- L – Logic level low
- Q – Output data
- T – Time
- V – Valid
- X – No longer a valid logic level
- Z – Float

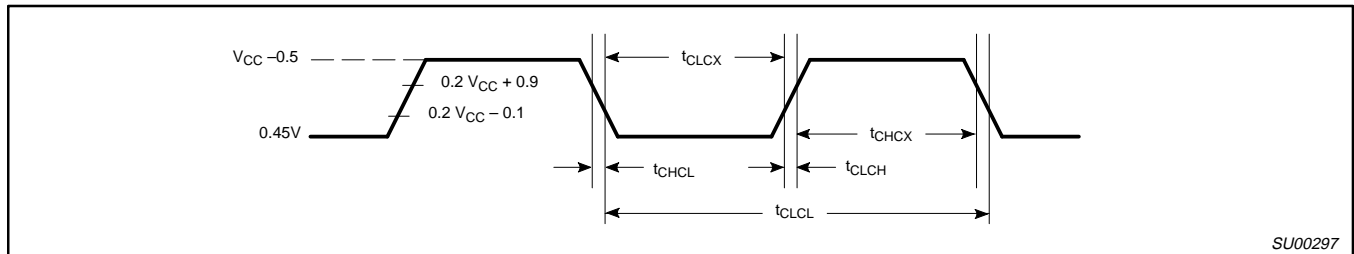

Figure 3. External Clock Drive

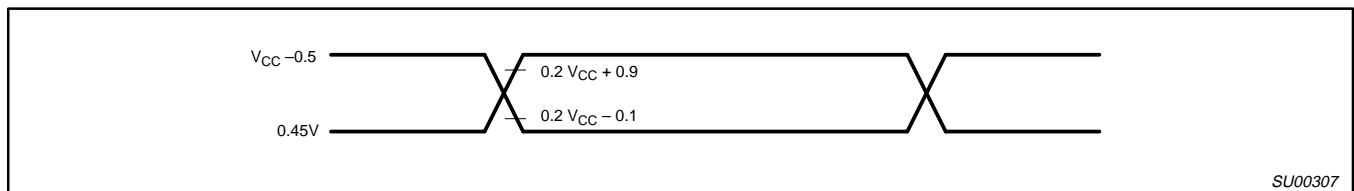

Figure 4. AC Testing Input/Output

Microcontroller with TrackPoint™ microcode from IBM

TPM749

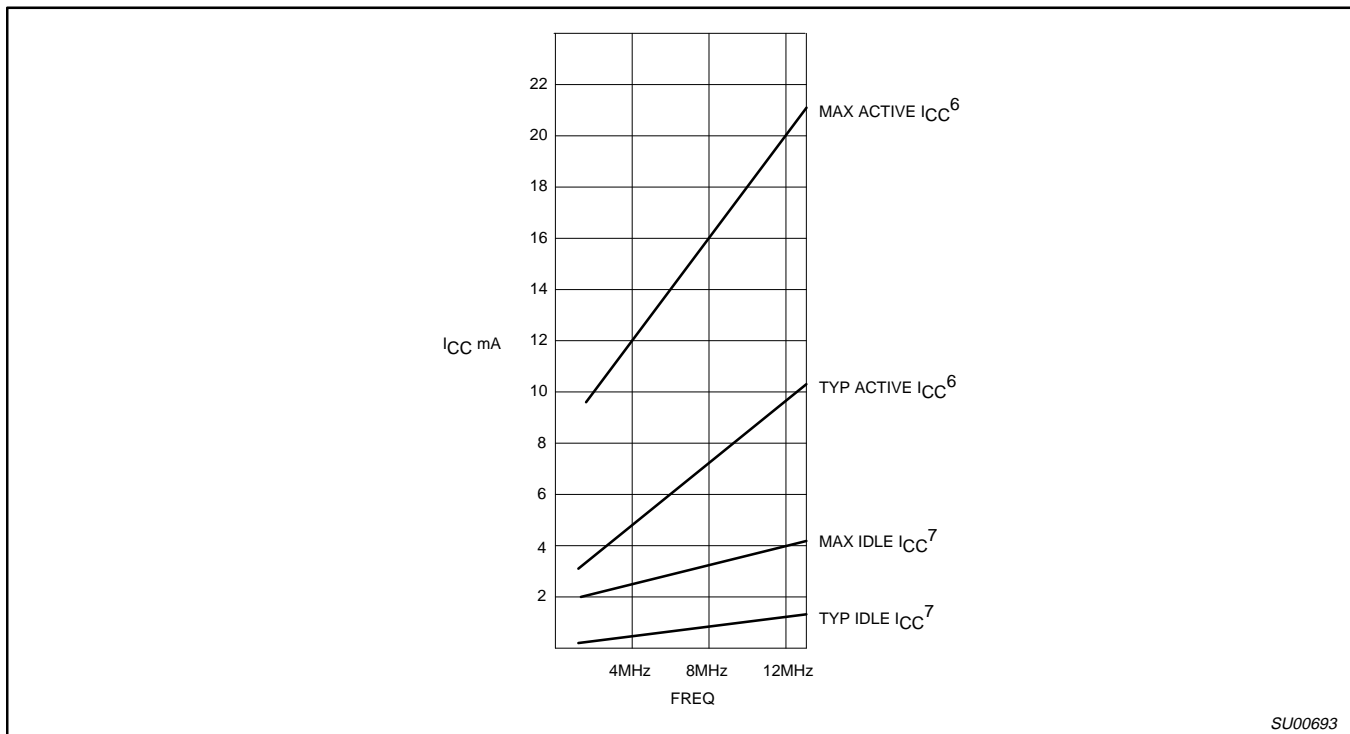

Figure 5. I_{CC} vs. FREQ
Maximum I_{CC} values taken at $V_{CC} = 5.5V$ and worst case temperature.
Typical I_{CC} values taken at $V_{CC} = 5.0V$ and $25^{\circ}C$.
Notes 6 and 7 refer to AC Electrical Characteristics.

SU00693

Microcontroller with TrackPoint™ microcode from IBM

TPM749

PLCC28: plastic leaded chip carrier; 28 leads; pedestal

SOT261-3

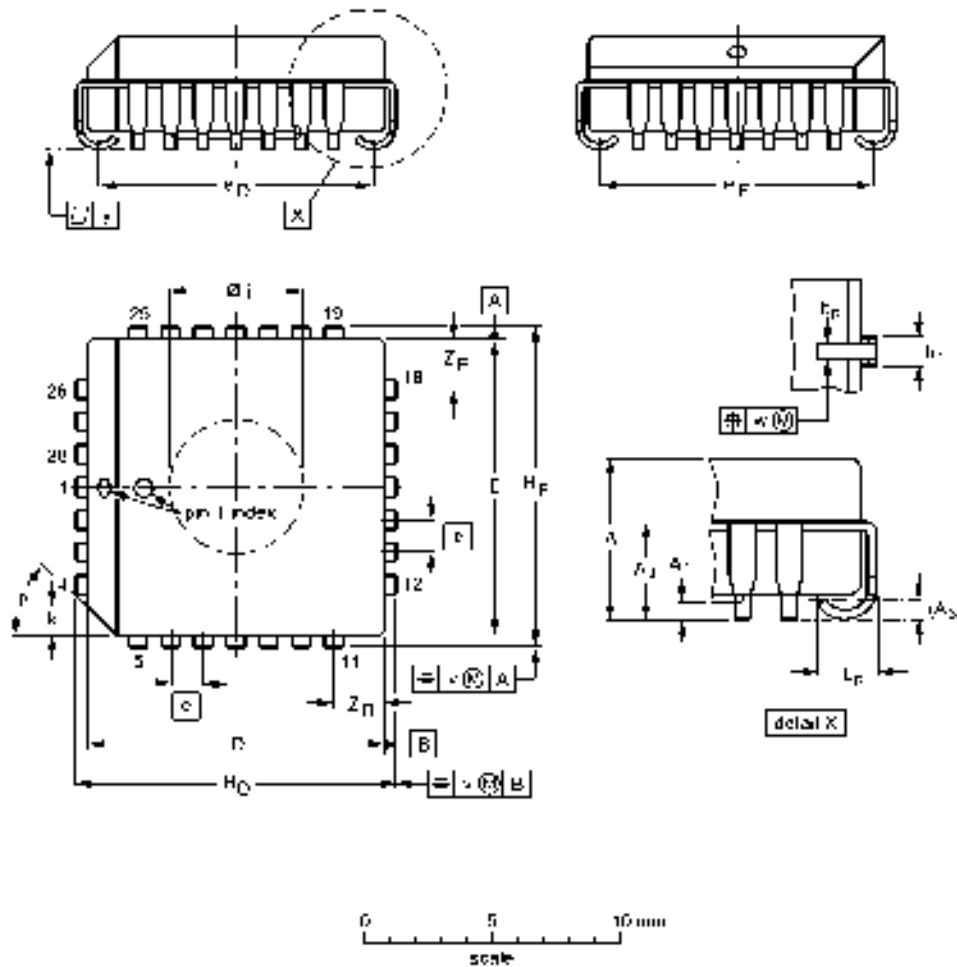

DIMENSIONS (millimetre dimensions are derived from the original inch dimensions)

UNIT	A	A ₁ min.	A ₃	A ₄ max.	b _p	Ø ₁	Ø ⁽¹⁾	E ⁽¹⁾	e	e _D	e _E	H _D	H _E	k	Ø ₁	L _p	v	w	y	Z _D ⁽¹⁾ max.	Z _E ⁽¹⁾ max.	ρ
mm	4.57 4.16	0.13	0.25	0.05	0.82 0.32	0.61 0.66	11.58 11.43	11.58 11.43	1.27	0.92 0.91	0.62 0.61	12.57 12.32	12.57 12.32	1.32 1.07	0.90 0.54	1.14 1.02	0.18	0.19	0.10	3.05	2.06	45°
inches	0.180 0.165	0.005	0.01	0.002	0.032 0.013	0.024 0.026	0.455 0.453	0.455 0.453	0.05	0.430 0.390	0.413 0.393	0.495 0.485	0.495 0.485	0.048 0.042	0.024 0.021	0.037 0.040	0.007	0.007	0.004	0.121	0.081	45°

Note
1. Plastic or metal protrusions of 0.01 inches maximum per side are not included

OUTLINE VERSION	REFERENCES			EUROPEAN PROJECTION	ISSUE DATE
	IEC	JEDEC	EIA/J		
SOT261-3		MO 047AB			00-11-17 03-02-25

Microcontroller with TrackPoint™ microcode from IBM

TPM749

SSOP28: plastic shrink small outline package; 28 leads; body width 5.3mm

SOT341-1

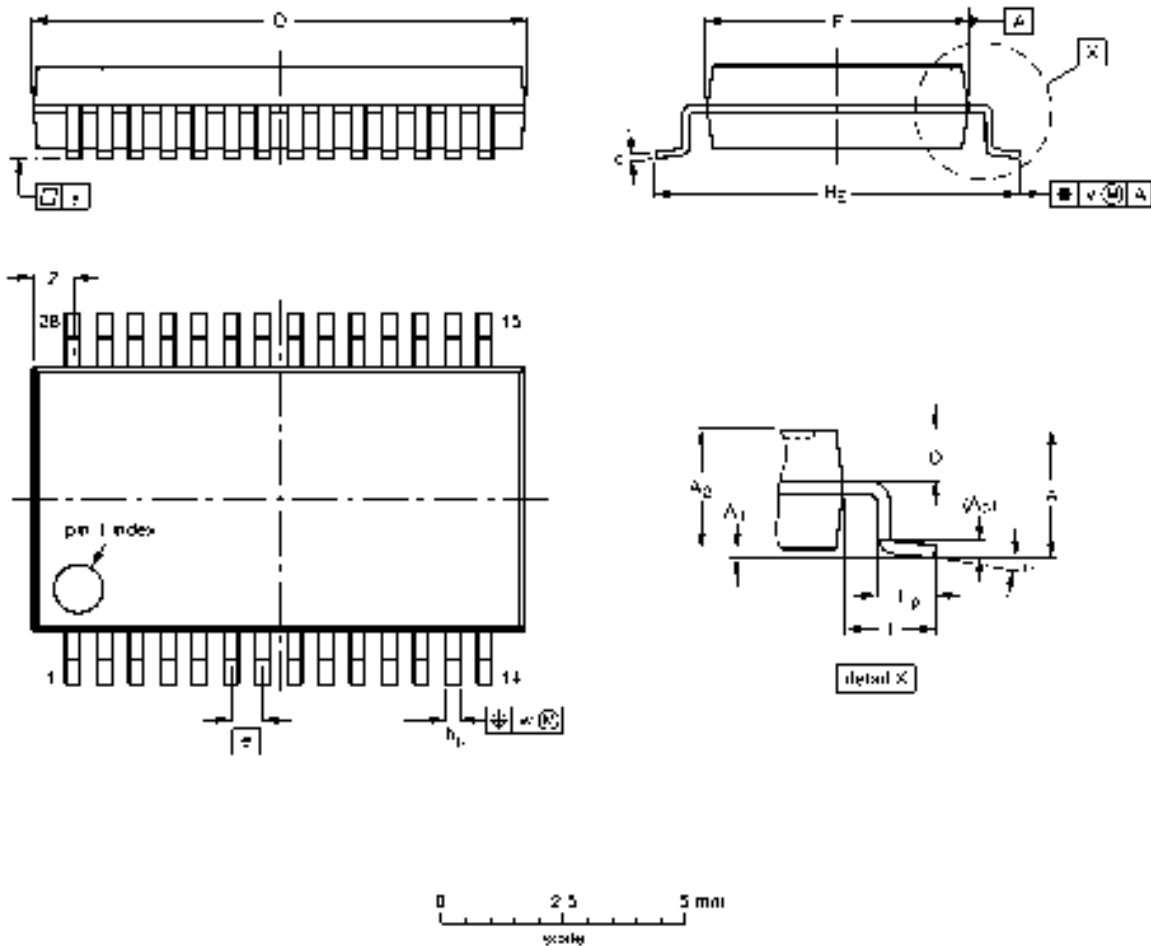

DIMENSIONS (mm are the original dimensions)

UNIT	Δ Max	A ₁	A ₂	A ₃	b _D	c	D ⁽¹⁾	E ⁽¹⁾	a	H _E	L	L _P	Q	v	w	y	z ⁽¹⁾	·1
mm	±0	0.21 0.05	1.90 1.65	0.25	0.35 0.23	0.20 0.09	10.4 10.0	5.4 3.0	0.06	7.8 7.6	1.25	1.00 0.60	0.9 0.7	0.2	0.13	0.1	1.1 0.7	0.7 0.7

Note
1. Plastic or metal protrusions of 0.20 mm maximum per side are not included

OUTLINE VERSION	REFERENCES			EUROPEAN PROJECTION	ISSUE DATE
	IEC	JEDEC	EIAJ		
SOT341-1		MO-150AH			93-05-08 95-02-04

Microcontroller with TrackPoint™ microcode from IBM

TPM749

NOTES

Microcontroller with TrackPoint™ microcode from IBM

TPM749

DEFINITIONS

Data Sheet Identification	Product Status	Definition
<i>Objective Specification</i>	Formative or in Design	This data sheet contains the design target or goal specifications for product development. Specifications may change in any manner without notice.
<i>Preliminary Specification</i>	Preproduction Product	This data sheet contains preliminary data, and supplementary data will be published at a later date. Philips Semiconductors reserves the right to make changes at any time without notice in order to improve design and supply the best possible product.
<i>Product Specification</i>	Full Production	This data sheet contains Final Specifications. Philips Semiconductors reserves the right to make changes at any time without notice, in order to improve design and supply the best possible product.

Philips Semiconductors and Philips Electronics North America Corporation reserve the right to make changes, without notice, in the products, including circuits, standard cells, and/or software, described or contained herein in order to improve design and/or performance. Philips Semiconductors assumes no responsibility or liability for the use of any of these products, conveys no license or title under any patent, copyright, or mask work right to these products, and makes no representations or warranties that these products are free from patent, copyright, or mask work right infringement, unless otherwise specified. Applications that are described herein for any of these products are for illustrative purposes only. Philips Semiconductors makes no representation or warranty that such applications will be suitable for the specified use without further testing or modification.

LIFE SUPPORT APPLICATIONS

Philips Semiconductors and Philips Electronics North America Corporation Products are not designed for use in life support appliances, devices, or systems where malfunction of a Philips Semiconductors and Philips Electronics North America Corporation Product can reasonably be expected to result in a personal injury. Philips Semiconductors and Philips Electronics North America Corporation customers using or selling Philips Semiconductors and Philips Electronics North America Corporation Products for use in such applications do so at their own risk and agree to fully indemnify Philips Semiconductors and Philips Electronics North America Corporation for any damages resulting from such improper use or sale.

Philips Semiconductors
811 East Arques Avenue
P.O. Box 3409
Sunnyvale, California 94088-3409
Telephone 800-234-7381

Philips Semiconductors and Philips Electronics North America Corporation register eligible circuits under the Semiconductor Chip Protection Act.
 © Copyright Philips Electronics North America Corporation 1996
 All rights reserved. Printed in U.S.A.

458291/4M/FP/pp16

Date of release: 05/96

Document order number:

9397 750 00817

Let's make things better.